

Thermo Pro 50

Engine-Off Coolant Heater for Specialty Vehicles and Equipment

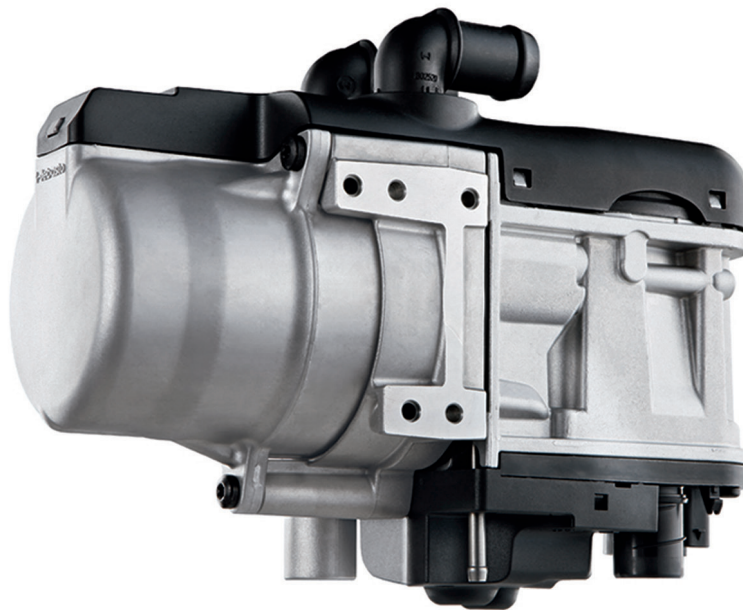

Coolant Heater Features:

- Auxilliary heating with up to 17,000 BTU/h of heating power
- The lightest heater in its class
- Tested to -50° F (-46° C)
- Compact size allows installation in a wide range of vehicles and equipment
- High product quality with long service life
- Low emissions due to efficient design
- Automatic high altitude adjustment up to 11,000 feet (3,350 m)
- Coolant inlet & outlet ports can be rotated 180°
- Remote mounted coolant pump

Be Ready For Work

The Thermo Pro 50 has been specially designed for use in specialty commercial vehicles and off-highway equipment. Its compact dimensions and lightweight design allow for installation in vehicles with limited space.

The heater pre-warms the engine eliminating cold starts, reducing harmful emissions, and increasing engine life. The heater's innovative features and compact size offer multiple installation options and significant fuel savings.

Technical Specifications

	Thermo Pro 50
Heating Capacity	8,500 – 17,000 BTU/h (2.5 – 5.0 kW)
Fuel Consumption	0.08 – 0.17 gal/h (0.3 – 0.65 l/h)
Fuels (Suitability for special fuels)	JP8, Diesel 1, Diesel 2, Arctic
Rated Voltage	24 V
Power Consumption	1.2 – 2.0 A (28 – 46 W)
Dimensions (L x W x H)	8.6 x 3.6 x 5.8 in (218 x 91 x 147 mm)
Weight	4.8 lbs (2.2 kg)

Technical specifications for circulating pump

	U4847
Coolant Flow	1.98 gal/min (7.5 l/h)
Power Consumption	.75 A (18 W)
Dimensions (L, ø)	4.3 L, ø 1.9 in (109 L, ø 48.5 mm)
Weight	0.7 lbs (0.3 kg)

Available Thermo Pro 50 Heater Kits:

Thermo Pro 50 Standard Kit (24 V): Part Number 5010666A

Thermo Pro 50 Heavy Duty/Off Highway Kit (24 V): Part Number 5010870A

Standard Kit Components:

- Heater
- Integrated Control Unit
- Circulation Pump U4847
- On/Off Switch
- Wiring Harness
- Fuel Metering Pump DP42
- Fuel Line
- Fuel Standpipe
- Exhaust System
- Installation Hardware
- Installation/Operation Instructions

Optional Accessories:

SmarTemp Control f_x Timer 2.0: Part Number 5010633C

SmarTemp Control f_x Timer 2.0 (optional):
for Thermo Pro 50 - Part Number 5010633C



- Programmable runtimes
- USB diagnostics
- Ergonomical design
- Large backlit LCD screen