

Webasto Coolant Heaters

Space Saving Heating Solutions for the RV Market

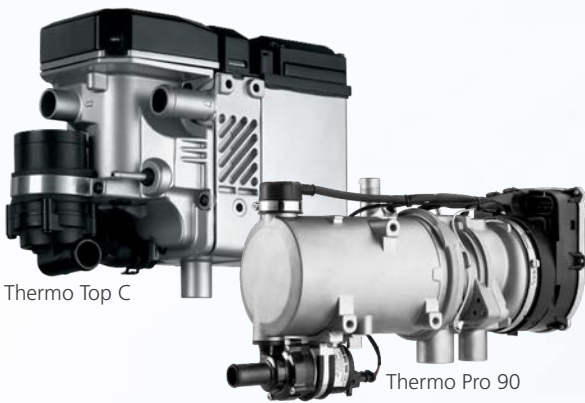

Thermo Top C

Thermo Pro 90

- Supply of warmth via the air outlets in the dashboard (Thermo Top C)
- Cabin heating and optional pre-heating of the engine
- Heating power up to 17,061 BTU/h (5 kW) TTC or up to 30,709 BTU/h(9 kW) Thermo Pro 90
- Less emissions due to engine pre-heating
- Compact design
- Very fast heat-up phase
- Quiet-running
- Low noise operation
- Diesel-fueled, directly fed from the tank



Feel the Drive



Technical Specifications

Thermo Top C	
Heating Capacity	8,600 – 17,200 BTU/h (2.5 – 5.0 kW)
Fuel	Diesel #1, Diesel #2 Arctic, Biodiesel B5 & B20
Fuel Consumption	0.08 – 0.16 gal/h (0.30 – 0.61 l/h)
Rated Voltage	12 V
Operating Voltage Range	10.5 – 15 V
Rated Input	3.8 Amps (46 W)
Water Flow	2 gal/min at 1.9 PSI (450 l/h at 0.13 bar)
Dimensions (L x W x H)	9.125 x 4.125 x 6.4 in (232 x 105 x 193 mm)
Weight	7 lbs (3.2 kg)

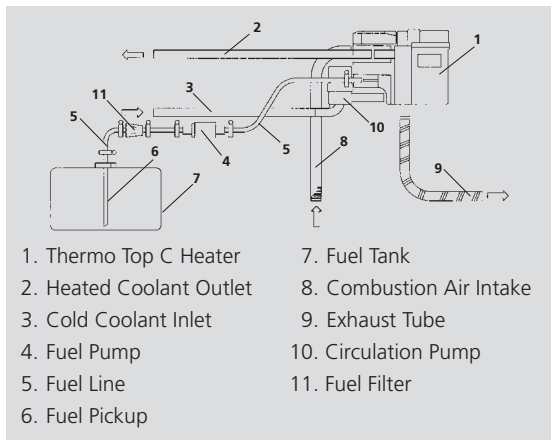
System Schematic



Technical Specifications

Thermo Pro 90	
Heating Capacity	6,100 – 26,000 BTU/h / 31,000 BTU/h (1.8 – 7.6 kW / 9.1 kW)
Fuel	JP8, Diesel 1, Diesel 2, Arctic, Biodiesel (PME)
Fuel Consumption	0.05 – 0.23 gal/h / 0.29 gal/h (0.2 – 0.9 l/h / 1.1 l/h)
Rated Voltage	12 or 24 V
Power Consumption (Part load - full load / Boost)	37 – 83 W / 90 W
Operational Temperature Range	- 40° to +176° F (- 40° to +80° C)
Dimensions (L x W x H)	15 x 5.5 x 9.13 in (381 x 140 x 232 mm)
Weight	10.8 lbs (4.9 kg)

System Schematic

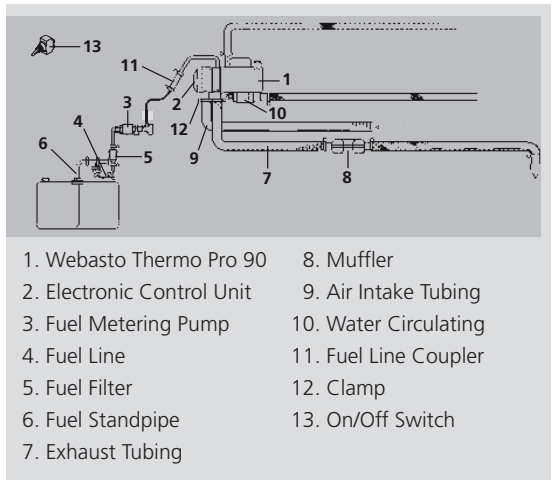

SmarTemp Control fx 2.0 (optional):
for Thermo Top C and Thermo Top 90
Part Number 5010753C



- Programmable run times
- Ergonomical design
- Large backlit LCD screen



Webasto Thermo & Comfort
North America, Inc.

15083 North Road
Fenton, Michigan 48430
USA

Toll Free: 800-860-7866
Phone: 810-593-6000

webasto.com