

# Thermo Top Evo

Next Generation Engine-Off Coolant Heater

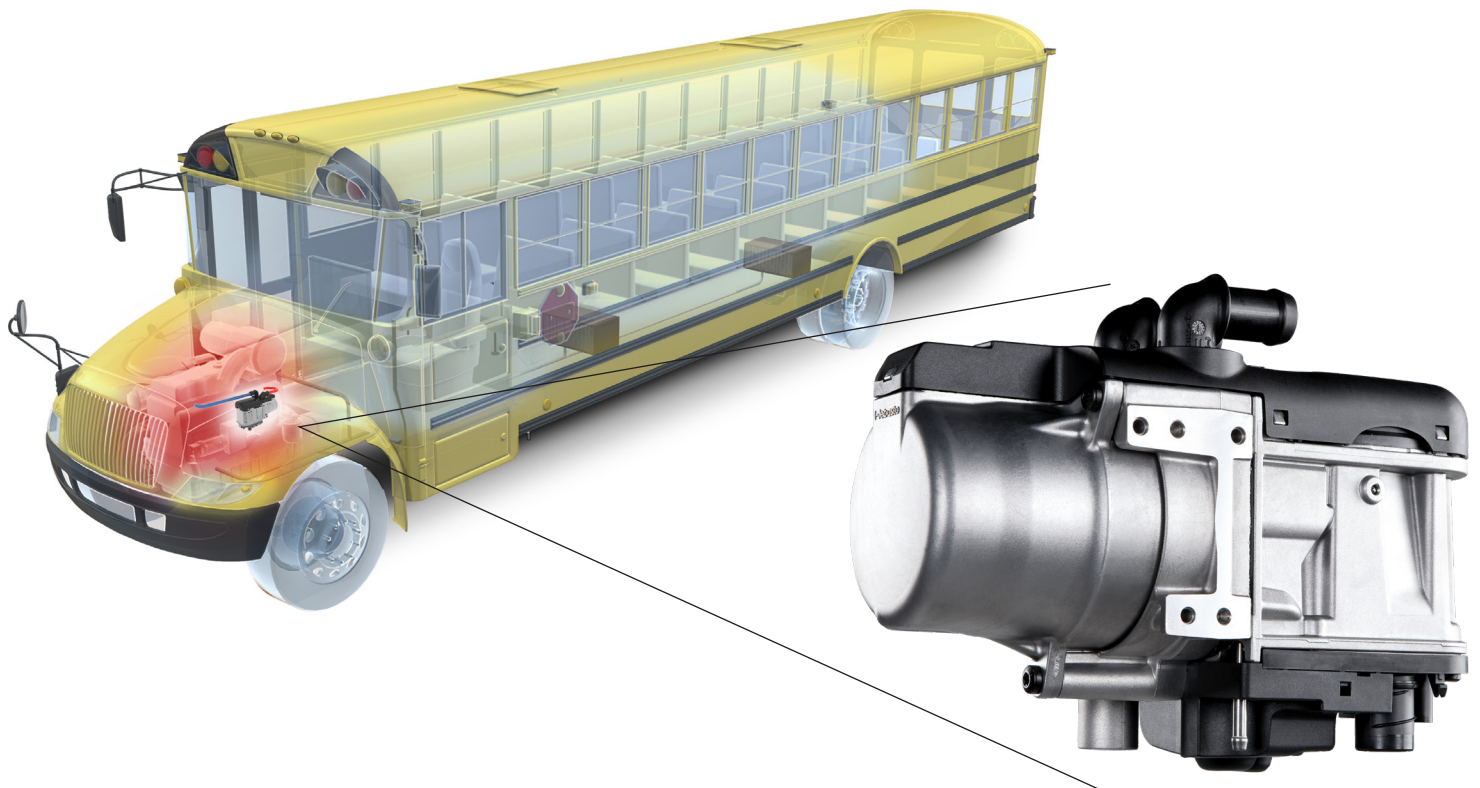

## Thermo Top Evo Benefits:

- More flexible installation options:
  - Coolant inlet & outlet connections can be rotated
  - Longer fuel line length
  - Higher maximum combustion air temperature
  - Universal controller harness
  - 1 standard, 4 available, mounting brackets
- Blink code diagnostics
- Quieter heater and fuel delivery operation

## Engine pre-heat, fuel savings and improve DPF performance

As the industry leader in efficient thermo technologies, Webasto is committed to continuous advancements that improve equipment performance and occupant comfort. Therefore, we're pleased to introduce the Thermo Top Evo.

Featuring advancements in the fuel delivery system, controls, diagnostics and flexible installation, the Thermo Top Evo improves the user experience and continues the Webasto heritage as a leader in idle-reduction, fuel efficiency and emission control.

## Technical Specifications

	Thermo Top Evo
Heating Flow [kW] (Partial Load / Full Load)	8,600 - 17,200 BTU/h (2.5 - 5.0 kW)
Fuel	Diesel, Arctic Diesel
Nominal Voltage (Suitability for special fuels)	12 V
Operating Voltage	10 to 16.5
Power Consumption (including coolant pump)	41 W
Power Consumption During Start-up at 12 V	14 Amps
Fuel Pump / Coolant Pump	DP 42 / U4847 econ
Noise Emission	61 dB
Dimensions (L x W x H) (without coolant pump)	8.54 x 3.58 x 5.79 in (217 x 91 x 147 mm)
Weight	4.6 lb. (2.1 kg)
Diagnostic	Blink Code, Diagnostic Tool

### Available Thermo Top Evo Heater Kits:

Thermo Top Evo Diesel School Bus Kit w/ Rocker Switch (12 V)

PN: 5013415A

## System Schematic

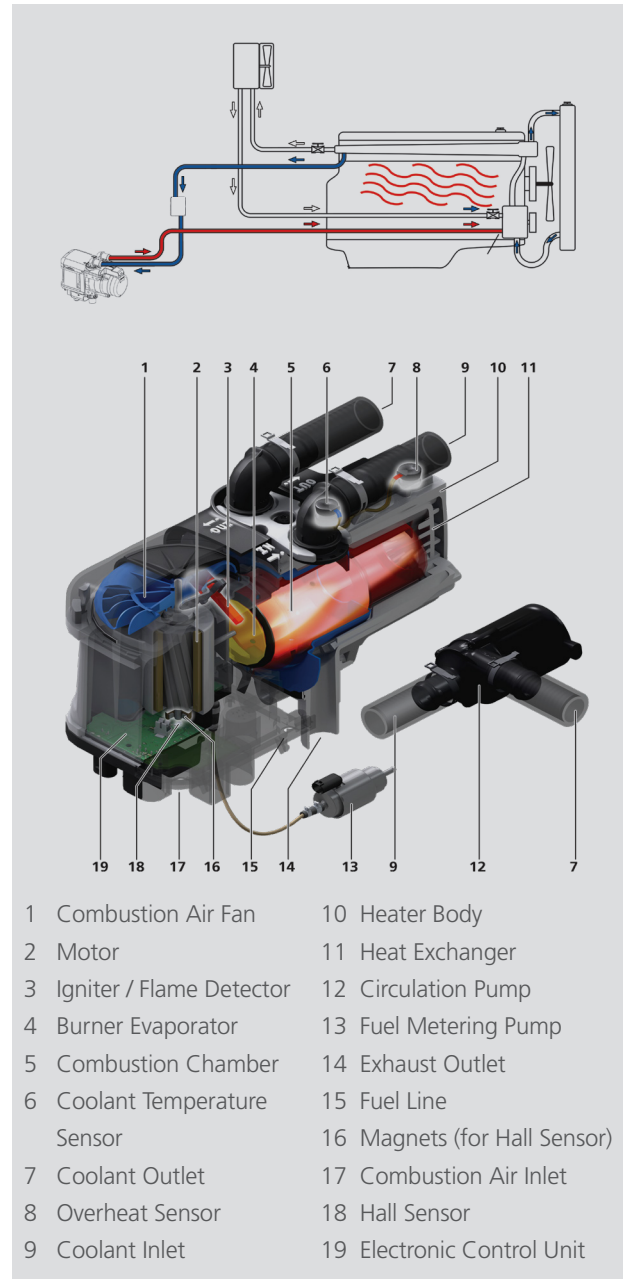

Upgrade to the new  
SmarTemp Control 3.0  
with adapter harness -  
Part number 5013932



### Optional Accessories:

#### SmarTemp Control 3.0:

Part Number 5013873

- Same unit controls air or coolant heater
- Programmable run times (Timers)
- Adjustable Low Voltage Disconnect (LVD)
- Preventive maintenance reminder
- Heater fault codes displayed



#### SmarTemp Control 3.0 Bluetooth:

Part Number 5013874

- Same features as SmarTemp 3.0
- Bluetooth connection to SmarTemp 3.0 App
  - View diagnostic information
  - Manage & control heater function
  - Link to techwebasto.com
  - Program settings of multiple units

Webasto Thermo & Comfort  
North America, Inc.

15083 North Road  
Fenton, Michigan 48430  
USA  
Toll Free: 800-860-7866  
Phone: 810-593-6000

[webasto-comfort.com](http://webasto-comfort.com)